

**RIBMNW24B-BCAI**

2.75" Track Mount BACnet® MS/TP Network Relay Device; One Discrete Output (20 Amp Relay SPDT + Override); Two Discrete Inputs (Dry Contact, Class 2); One Analog Input (T2/T3 Thermistor / 0-5 Vdc / 0-10 Vdc); 24 Vac/dc Power Input; **Optional End of Line Resistor (EOL) Included.**

**RIBTW24B-BCAI**

Enclosed BACnet® MS/TP Network Relay Device; One Discrete Output (20 Amp Relay SPDT + Override); Two Discrete Inputs (Dry Contact, Class 2); One Analog Input (T2/T3 Thermistor / 0-5 Vdc / 0-10 Vdc); 24 Vac/dc Power Input; **Optional End of Line Resistor (EOL) Included.**

**Network Compatible Relays**

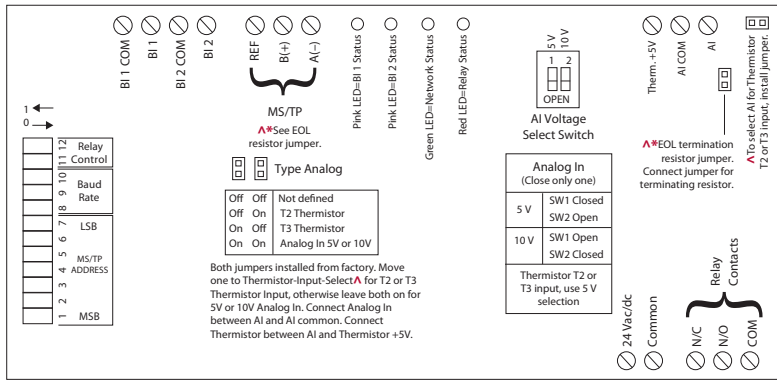
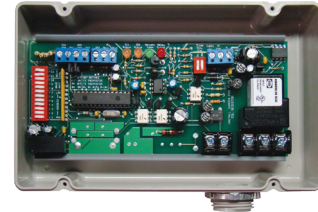

**Specifications**

- # Relays & Contact Type:** One (1) SPDT Continuous Duty Coil
- Expected Relay Life:** 10 million cycles minimum mechanical
- Operating Temperature:** -30 to 140° F
- Humidity Range:** 5 to 95% (noncondensing)
- Operate Time:** 18ms
- Green LED:** Network Communication
- Red LED:** Relay Status
- Pink LED:** BI 1
- Pink LED:** BI 2
- Dimensions:** 6.25" x 2.75" x 1.75" (RIBMNW24B-BCAI) 4.28" x 7.00" x 2.00" with .75" NPT Nipple (RIBTW24B-BCAI)
- Track Mount:** MT212-6 Mounting Track Provided
- Approvals:** UL Listed, UL916, C-UL
- Housing Rating:** UL Listed, NEMA 1, C-UL, CE Approved, UL Accepted for Use in Plenum, Also available NEMA 4 / 4X
- Gold Flash:** No
- Relay Override Switch:** DIP Switch Control
- Network Media:** Twisted Pair 22-24AWG, shielded recommended
- Terminations:** Functional Devices product installed at both ends of the MS/TP network – Use 120 Ω end of line resistors. All other cases – Follow instructions from the device installed at the end of the MS/TP network.
- Polarity:** Network is polarity sensitive
- Baud Rate:** 9600, 19200, 38400, 57600, 76800, 115200 (DIP Switch Selectable)

- Contact Ratings:**
  - 20 Amp Resistive @ 277 Vac
  - 20 Amp Ballast @ 120/277 Vac (N/O)
  - 10 Amp Ballast @ 120/277 Vac (N/C)
  - Not rated for Electronic Ballast*
  - 10 Amp Tungsten @ 120 Vac (N/O)
  - 1110 VA Pilot Duty @ 277 Vac
  - 770 VA Pilot Duty @ 120 Vac
  - 2 HP @ 277 Vac
  - 1 HP @ 120 Vac
- Power Input Ratings:**
  - 81 mA @ 24 Vdc
  - 111 mA @ 24 Vac

- Notes:**
- MS/TP Address & Baud Rate must be set prior to power up via DIP switches.
  - Device ID will default to 277XXX where XXX is the MS/TP Address.

MS/TP Address - 004 Device ID - 277004	MS/TP Address - 121 Device ID - 277121
---	---

- Examples:
- Device ID can be changed via network command. Once changed, it will no longer default to 277XXX. (MS/TP Address & Device ID must be unique.)
- Order NEMA 4 housing by adding "-N4" to end of model number. (RIBTW24B-BCAI)
- This model utilizes: BO 1 (Relay output), BI 1 (Dry contact digital input), BI 2 (Dry contact digital input), AI 1 (Analog input)
- Device Instance changed via Object Identifier Property of Device Object
- Thermistor Type 2 (T2) Precon 10 K @ 77°F (25°C) PN ST-R24, Model 24, (or equivalent.) Thermistor Type 3 (T3) Precon 10 K @ 77°F (25°C) Model 3, (or equivalent.) Thermistor not included.
- If date code is prior to 083012, Version 1.03 or earlier:
  - For both T2 and T3, MIN\_PRE\_VAL must be set to -36 (real value) and MAX\_PRE\_VAL must be set to 987 (real value).
  - 35 to 100°C range in 1° steps.
- If date code is 083012 or later, Version 1.05:
  - For both T2 and T3, MIN\_PRE\_VAL must be set to -36 (real value) and MAX\_PRE\_VAL must be set to 66.3 (real value) for Celcius. For Fahrenheit, MIN\_PRE\_VAL must be set to -32.8 (real value) and MAX\_PRE\_VAL must be set to 151.34 (real value).
  - 35 to 10°C range in 1° steps / -31 to 50°F range in 1.8° steps
  - 10 to 32°C range in 0.1° steps / 50 to 90°F range in 0.18° steps
  - 32 to 100°C range in 1° steps / 90 to 212°F range in 1.8° steps
- For all versions, raw analog default settings are 0 and 1023 (real), respectively. Units default to 95 (no units).
- When connecting 24 Vac to both this device and a half-wave device, damage to device can occur.**
  - Option 1:** Use separate transformers for each device.
  - Option 2:** Add diode between devices, see Option 2 note below.^^
- PIC Statement available on website. [http://www.functionaldevices.com/pdf/datasheets/pics/BACnet-BCAI\\_PIC\\_12\\_18\\_12.pdf](http://www.functionaldevices.com/pdf/datasheets/pics/BACnet-BCAI_PIC_12_18_12.pdf)
- Or scan QR code with your smart phone.

DIP Switches*			Baud Rate
<b>8</b>	<b>9</b>	<b>10</b>	
0	0	0	9600
0	0	1	19200
0	1	0	38400
0	1	1	57600
1	0	0	76800
1	0	1	115200

DIP Switches*		Relay State**
<b>11</b>	<b>12</b>	
1	0	Auto
X	1	Override on
0	0	Override off

\* 0 = Open ; 1 = Closed  
\*\* Device must be powered for override

All other combinations=9600 baud

• Dry contact digital input is a general purpose input that is not tied to the relay internally. Can be used with any dry contact switching device, such as a current sensor, to feed back to the network.

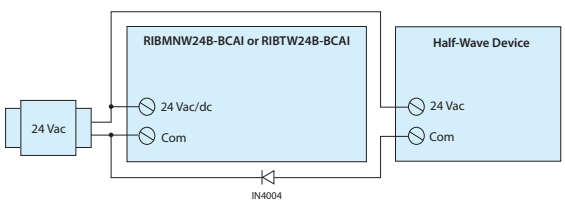

^^ Option 2:  
Add diode on 24 Vac power (Com) interconnection between devices. Band on diode faces towards -BCAI.

